

Pos.Nr. Pos.no. Position	Beschreibung Description Désignation	Preisgruppe Price bracket Catégorie de prix	Art.-Nr. Art.no. Réf.
1	Hafringsatz DC	85622	19
2	Schraube M1.6 x 7	85730	2
3	Schraube 2.2 x 9.5 mm	85808	2
4	Zugfeder	86208	2
5	Zahnrad Z=19/12 M 0.4	86471	2
6	Schneckenrad	86490	4
7	Zahnrad (ohne Abbildung)	86491	2
8	Kardanschale kurz	87129	3
9	Kardanwelle	87214	4
10	Lokpfeife	88002	6
11	Puffer flach	88502	4
12	Puffer gewölbt	88503	4
13	Universalkupplung	89282	5
14	Lager für Schneckenachse	89749	6
15	Brückenstecker	100644	7
16	Atrappenrahmen klein	107808	3
17	Zahnrad Z=16 (ohne Abbildung)	109251	2
18	Drahtlampe 16V	109321	10
19	Kinematik	113088	2
20	Teilesatz	113089	12
21	Teilesatz	113090	12
22	Platine	113091	43
23	Motor	113092	57
24	Schneckensatz kpl.	113093	24
25	Gehäuse kpl.	113094	53
26	Zurüstbeutel	113095	24
27	Radsatz ohne Hafring	113096	18
28	Getriebe	113097	18
29	Getriebeboden	113098	5
30	Radsatz mit Hafringen	113099	20
31	Teilesatz	113100	18
32	Teilesatz	113101	6
33	Teilesatz	113102	12
35	Radkontakt	113104	4
36	Klingel	113105	2
37	Führerstand	113106	3
38	Grundrahmen	113107	30
39	Batteriekasten	114527	6
40	Anlaufscheibe (o. Abb.)	113942	2
41	Scheibenwischer	114532	2
42	Teilesatz	114533	6
43	Teilesatz (o. Abb.)	114534	6
Abweichende Teile 63382 Sound			
44	FK-Schraube M2x4,5/7,5	85771	3
45	Feder	86202	2
46	Klebeband (o. Abb.)	112629	2
47	AC-Getriebe	113112	12
48	AC-Getriebeboden	113113	8
49	Radsatz mit 2 Hafringen	114617	16
Abweichende Teile 63383			
50	Scheibenwischer	113518	2
51	Gehäuse kpl.	114535	53
52	Türgriffstange	114536	2
~ Wechselstrom / AC			
53	Decoder Motorola m. Lastr. last.	10738	---
54	AC-Flüsterschleifer kurz	40064	---
55	Hafringsatz *AC*	85623	16
56	FK-Schraube M x 4,5/7,5	85771	3
57	Feder	86202	2
58	Schraube	113069	2
59	Grundrahmen	113109	30
60	Motor	113110	57
61	Radsatz ohne Zahnrad	113111	16
62	AC-Getriebeboden	113113	8
63	Radsatz ohne Hafringe	113114	18
64	Radsatz mit Hafringen	113115	20

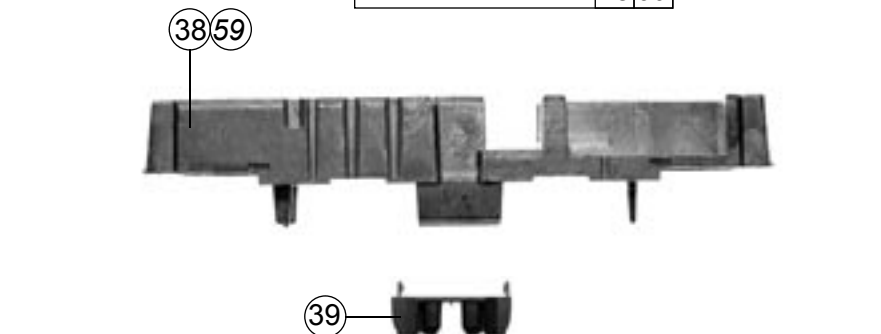

Pos.Nr. Pos.no. Position	Beschreibung Description Désignation	Preisgruppe Price bracket Catégorie de prix	Art.-Nr. Art.no. Réf.
1	Set with traction tires DC	85622	19
2	Screw M 1.6 x 7	85730	2
3	Screw 2.2 x 9.5	85808	2
4	Spring	86208	2
5	Gear z=19/12 M 0,4	86471	2
6	Worm gear	86490	4
7	Gear (no illustration)	86491	2
8	Cardan shell short	87129	3
9	Cardan Shaft	87214	4
10	Loco whistle	88002	6
11	Buffer flat	88502	4
12	Buffer vaulted	88503	4
13	Universal coupling	89282	5
14	Bearing for Worm axle	89749	6
15	Connector	100644	7
16	Push in part set, smal	107808	3
17	Gear z=16 (no illustration)	109251	2
18	Light bulb 16V	109321	10
19	Kinematics	113088	2
20	Parts set	113089	12
21	Parts set	113090	12
22	Printed circuit	113091	43
23	Motor	113092	57
24	Worm set assembly	113093	24
25	Casing assembly	113094	53
26	Bag with accessories	113095	24
27	Wheelset without traction tires	113096	18
28	Gear set	113097	18
29	Gear bottom	113098	5
30	Wheelset with traction tires	113099	20
31	Parts set	113100	18
32	Parts set	113101	6
33	Parts set	113102	12
35	Wheel contact	113104	4
36	Bell	113105	2
37	Drivers cab	113106	3
38	Main frame	113107	30
39	Battery case	114527	6
40	Washer disk (no ill.)	113942	2
41	Wind screen wiper	114532	2
42	Parts set	114533	6
43	Parts set (no ill.)	114534	6
Variant Parts 63382 Sound			
44	Screw M2x4,5/7,5	85771	3
45	Spring	86202	2
46	Tape (no ill.)	112629	2
47	Gear AC	113112	12
48	Gear bottom AC	113113	8
49	Wheelset with traction tires	114617	16
Variant Parts 63383			
50	Wind screen wiper	113518	2
51	Casing assembly	114535	53
52	Door handle bar	114536	2
~ Wechselstrom / AC			
53	Decoder „Motorola“	10738	---
54	Whisper wiper short	40064	---
55	Set with traction tires	85623	16
56	FK-Screw MX 4,5/7,5	85771	3
57	Spring	86202	2
58	Screw	113069	2
59	Main frame	113109	30
60	Motor	113110	57
61	Wheelset without Gear	113111	16
62	Gear bottom AC	113113	8
63	Wheelset without traction tires	113114	18
64	Wheelset with traction tires	113115	20

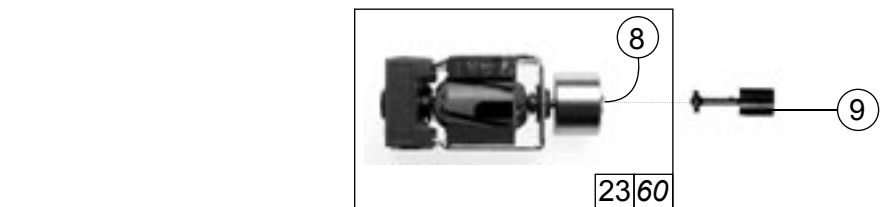
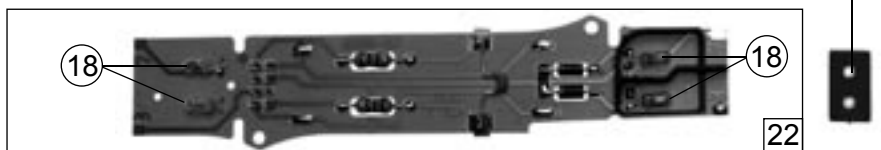
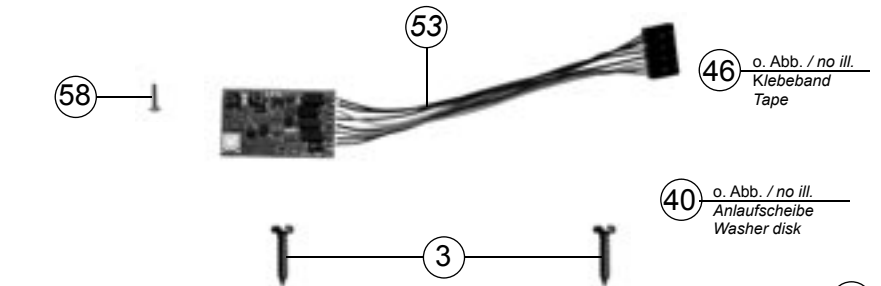
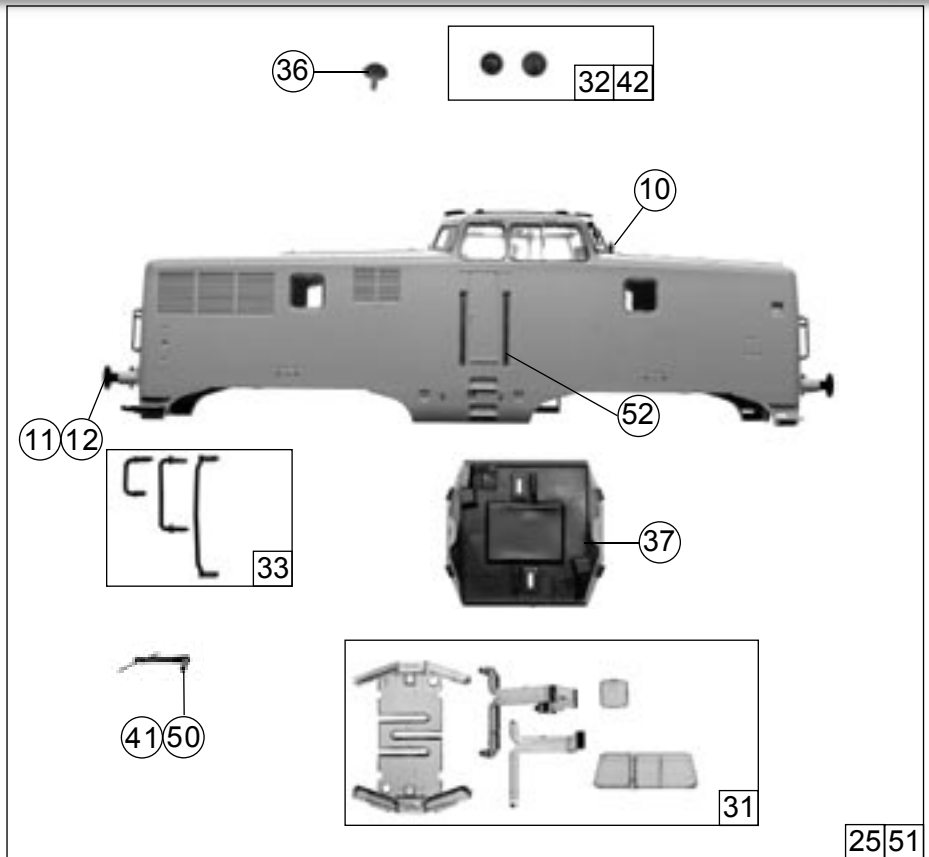
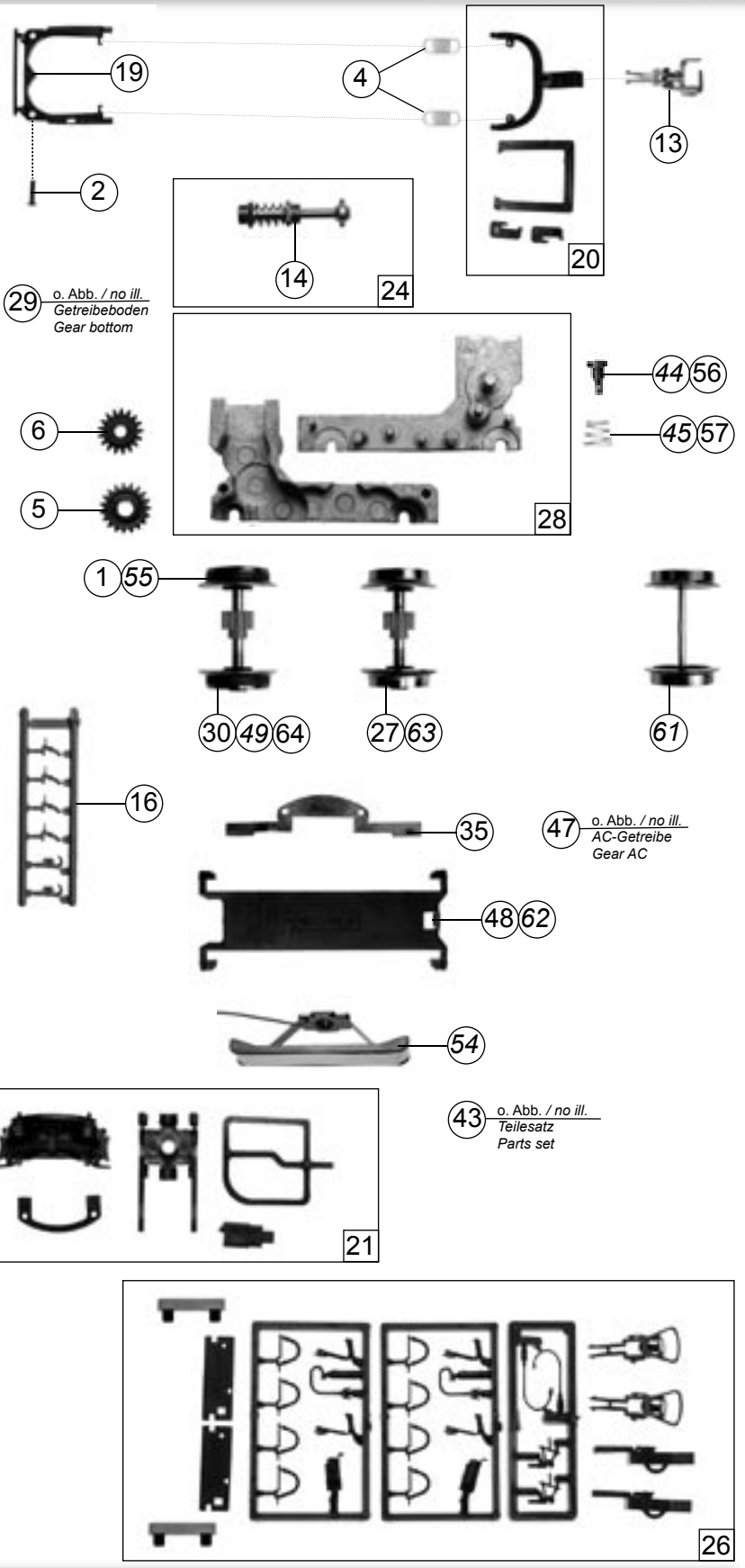

Ersatzteile erhalten Sie bei Ihrem Fachhändler, Ihrer Landesvertretung, oder bei:
You can order your Replacement Parts at your local dealer, your country representative, or:
 Passez commande des pièces détachées chez votre détaillant, chez le S.A.V. de votre importateur national ou en direct au S.A.V.
 ROCO:

ROCO Modellspielwaren
VertriebsgmbH & Co. Handels KG
 - Service -
Georg-Wrede-Straße 49
D-83395 Freilassing
 ☎ +49 / (0)86 54 / 47 63 0
 Fax: +49 / (0)86 54 / 47 63 50
 E-Mail: service@roco-online.de