

Symbolische Darstellung  
Symbolic Illustration

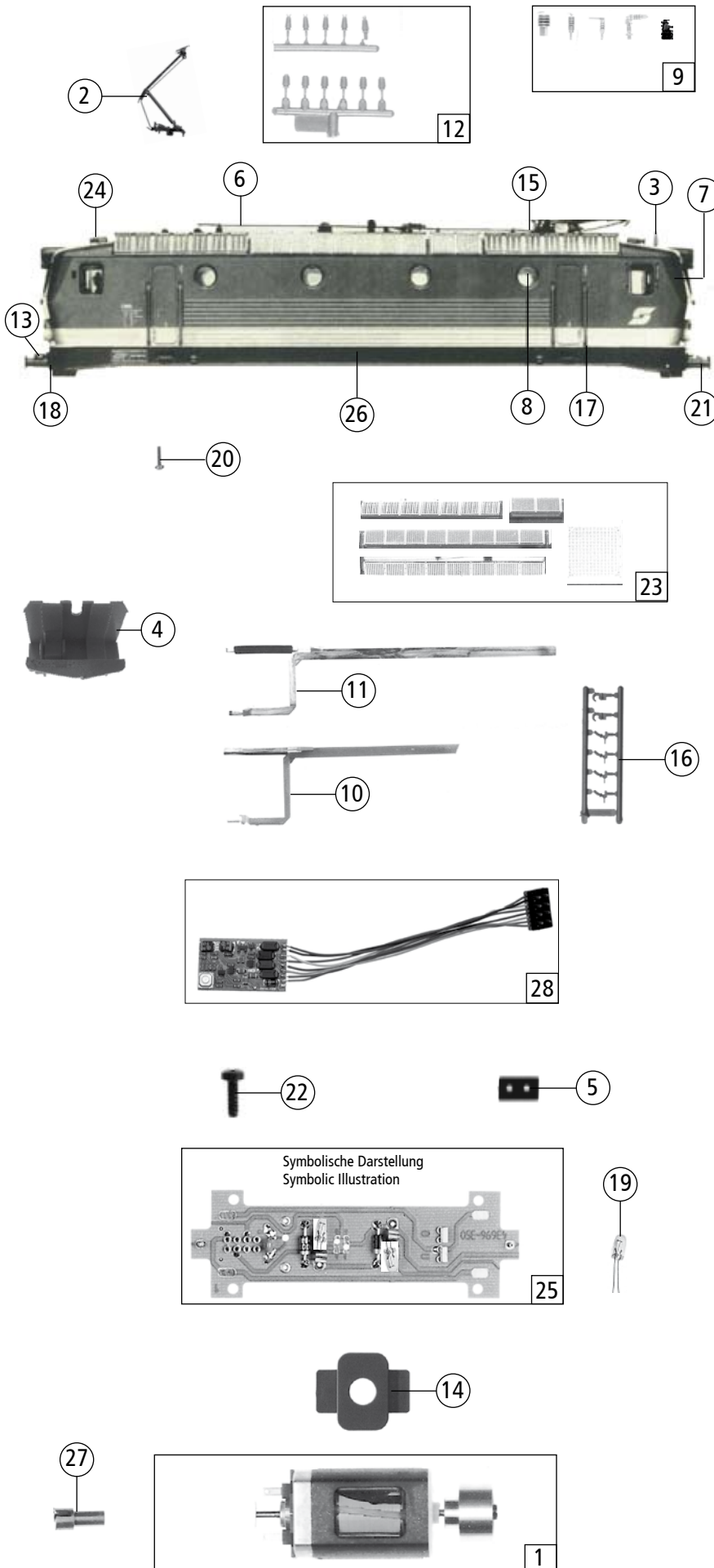

Pos. Nr. Pos.no.	Beschreibung Description	Art.-Nr. Art.no.	Preisgruppe Price bracket
62443	ÖBB 1044	≡	
68443	ÖBB 1044	~	
1	Motor Motor	85117	57
2	Pantograph Pantograph	85382	38
3	Antenne Antenna	88030	4
4	Führerstand Drivers cab	93359	6
5	Brückenstecker Connector	100644	7
6	Hauptleitung Main roof wire	101470	10
7	Stirnfenster Front window	101473	5
8	Seitenfenster Side window	101474	5
9	Isolatorsatz Insulator set	101477	12
10	Lichtleiter weiss Light transmission bar white	105174	5
11	Leuchtstab rot Light transmission bar red	105175	5
12	Isolatorsatz Insulator set	105176	12
13	Puffertritt Buffer step	105223	2
14	Distanzplättchen Shim	105764	2
15	Hebeantrieb Pantograph cylinder	107029	2
16	Attrappenrahmen klein Push in part short	107808	3
17	Türgriff Door handle	107859	2
18	Rangiertritt Hump step	107860	2
19	Drahtlampe 16V Light 16V	109321	10
20	Schraube M1.6X5 Screw M1.6X5	110008	2
21	Puffer eckig Buffer angular	114753	3
22	GF - Schraube M2X6 Screw M2X6	114828	2
23	TS - Lüftergitter Part set cover	120249	22
24	Sirene Airhorn	121170	3
25	Platine komplett Printed circuit assembl	126558	45
26	Gehäuse komplett Betr. Nr. 1144 275-5 Body assembly Betr. No. 1144 275-5	126678	70
27	Kardanschale lang Cardan bearing long	87066	3
<b>AC - Wechselstrom</b>			
28	Decoder Motorola Decoder Motorola	10738	---

Änderungen in Konstruktion und Ausführung vorbehalten  
We reserve the right to change the construction and specification

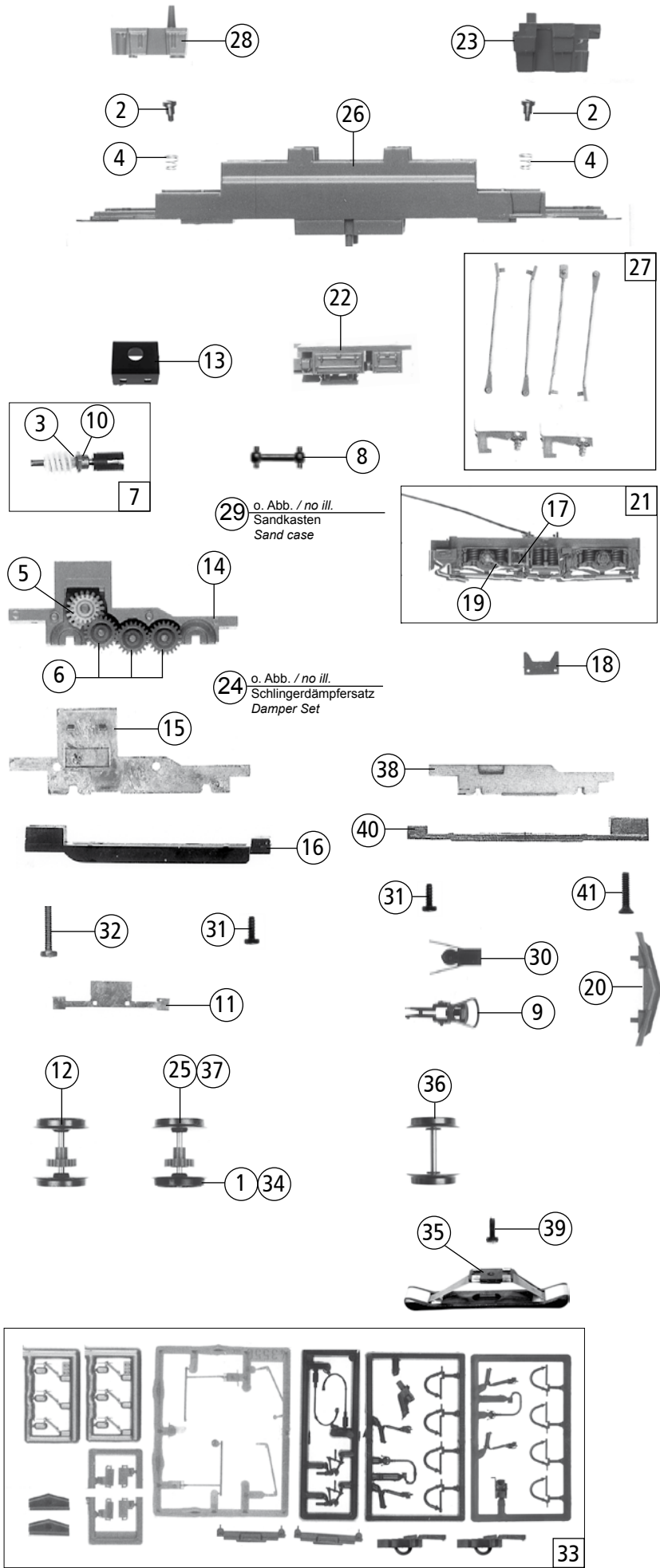

Pos. Nr. Pos. no.	Beschreibung Description	Art.-Nr. Art. no.	Preisgruppe Price bracket
62443	ÖBB 1044		
68443	ÖBB 1044	~	
1	Hafringsatz 10Stk. 12,9-14,6mm Setz with traction tires 10 pieces	40070	---
2	FK - Schraube mit Gewindeauslauf FK - Screw	85704	3
3	Beilagscheibe Washer	86108	2
4	Feder Spring	86202	2
5	Schenkenzahnrad Worm gear	86413	4
6	Zahnrad Z=21 G/M=0,4 Gear Z= 21 G/M=0,4	86414	2
7	Schneckenatz Worm set	86978	24
8	Kardanwelle 9,5mm Cardan shaft 9,5mm	87154	2
9	Standardkupplung Standard coupling	89246	5
10	Lager für Schneckenachse Bearing for worm axle	89749	6
11	Radstromkontakt Wheel current contact strip	89856	3
12	Radsatz m. Zahnrad ohne Haftring Wheelset w. gear without traction tyre	90387	18
13	Schneckenkammerdeckel Worm cover	93133	4
14	Getriebe Gear	93150	25
15	Getriebedeckel Gear cover	93151	10
16	Getriebeboden Gear bottom	93152	16
17	Treppe Stair	94300	3
18	Kontakthalter Contactholder	94302	2
19	Leitung Wire	94316	2
20	Schienenräumer Rail guard	94319	6
21	Drehgestellblende kpl. Bogie side frame cover ass.	105181	37
22	Batteriekasten Batterie case	107849	5
23	Gewicht groß Weight big	107853	22
24	Schlingerdämpfer links+rechts o. Abb. Damper set no ill.	107857	6
25	Radsatz m. 2Hafringen Wheelset w. 2 traction tires	108110	20
26	Grundrahmen Base frame	112564	30
27	Bremshebelstangensatz Brake lever set	112633	18
28	Gewicht klein Weight small	112634	20
29	Sandkasten mit Loch o. Abb. Sand case no ill.	112637	2
30	Kupplungskammer Coupling holder	113041	3
31	GF - Schraube M2x6 GF - Screw M2x6	114828	2
32	GF - Schraube M2x10 GF - Screw M2x10	114854	2
33	Zurüstbeutel Bag with accessories	126681	24
<b>AC - Wechselstrom</b>			
34	Hafringsatz 10Stk. 12,5-15,3mm Set with tractiontires 10pieces	40075	---
35	Schleifer Slider	86031	---
36	Radsatz o. Haftring o. Zahnrad Wheelset without traction tyre without gear	90389	16
37	Radsatz m. Haftring m. Zahnrad Wheelset w. traction tires w. gear	90390	20
38	Blindgetriebe Blind gear	101472	25
39	GF - Schraube M1,6x4 GF - Screw M1,6x4	114850	2
40	Getriebeboden AC Gear bottom AC	122720	12
41	SK - Schraube M2x10 SK - Screw M2x10	123744	2

Ersatzteile erhalten Sie bei Ihrem Fachhändler, oder Ihrer Landesvertretung.

You can order your Replacement Parts at your local dealer, your country representative.